



**BUILDING CODE COMPLIANCE OFFICE (BCCO)  
PRODUCT CONTROL DIVISION**

**MIAMI-DADE COUNTY, FLORIDA  
METRO-DADE FLAGLER BUILDING  
140 WEST FLAGLER STREET, SUITE 1603  
MIAMI, FLORIDA 33130-1563  
(305) 375-2901 FAX (305) 375-2908**

**NOTICE OF ACCEPTANCE (NOA)**

**Sto Corporation.  
6175 Riverside Drive. S.W.  
Atlanta GA 30331**

**SCOPE:** This NOA is being issued under the applicable rules and regulations governing the use of construction materials. The documentation submitted has been reviewed by Miami-Dade County Product Control Division and accepted by the Board of Rules and Appeals (BORA) to be used in Miami Dade County and other areas where allowed by the Authority Having Jurisdiction (AHJ).

This NOA shall not be valid after the expiration date stated below. The Miami-Dade County Product Control Division (In Miami Dade County) and/or the AHJ (in areas other than Miami Dade County) reserve the right to have this product or material tested for quality assurance purposes. If this product or material fails to perform in the accepted manner, the manufacturer will incur the expense of such testing and the AHJ may immediately revoke, modify, or suspend the use of such product or material within their jurisdiction. BORA reserves the right to revoke this acceptance, if it is determined by Miami Dade County Product Control Division that this product or material fails to meet the requirements of the applicable building code.

This product is approved as described herein, and has been designed to comply with the Florida Building Code including the High Velocity Hurricane Zone.

**DESCRIPTION: Sto HI-CM Exterior Insulation and Finish System – L.M.I.**

**APPROVAL DOCUMENT:** Drawing No. **Sto HI-CM**, Sheets 1 through 3 of 3, titled "Sto HI-CM for Large Missile Impact Resistance" dated 03/29/07, with no revisions, prepared by STO Corporation, signed and sealed by Christopher B. Shiver, P.E., bearing the Miami-Dade County Product Control renewal stamp with the NOA number and expiration date by the Miami-Dade County Product Control Division.

**MISSILE IMPACT RATING: Large and Small Missile.**

**LABELING:** Each component shall bear a permanent label with the manufacturer's name or logo, city, state and following statement: "Miami-Dade County Product Control Approved or MDCPCA", unless otherwise noted herein.

**LIMITATIONS:** This system is not to be used on horizontal surfaces exposed to weather except as a soffit, it is intended to be used on wall systems only.

**RENEWAL** of this NOA shall be considered after a renewal application has been filed and there has been no change in the applicable building code negatively affecting the performance of this product.

**TERMINATION** of this NOA will occur after the expiration date or if there has been a revision or change in the materials, use and/or manufacture of the product or process. Misuse of this NOA as an endorsement of any product, for sales, advertising or any other purposes shall automatically terminate this NOA. Failure to comply with any section of this NOA shall be cause for its termination and removal.

**ADVERTISEMENT:** The NOA number preceded by the words Miami-Dade County, Florida, and followed by the expiration date may be displayed in advertising literature. If any portion of the NOA is displayed, then it shall be done in its entirety.

**INSPECTION:** A copy of this entire NOA shall be provided to the user by the manufacturer or its distributors and shall be available for inspection at the job site at the request of the Building Official.

This renews NOA # **05-0921.07** and consists of this page 1, evidence page E-1 as well as the approval document mentioned above.

The submitted documentation was reviewed by **Jaime D. Gascon, P.E.**



*J. Gascon  
4/5/07*

**NOA No: 07-0104.05  
Expiration Date: January 08, 2012  
Approval Date: April 26, 2007**

**Sto Corporation.**

**NOTICE OF ACCEPTANCE: EVIDENCE SUBMITTED**

**A DRAWINGS**

1. Drawing No. **Sto HI-CM**, Sheets 1 through 3 of 3, titled "Sto HI-PLY EIFS for Large Missile Impact Resistance" dated 03/29/07, with no revisions, prepared by STO Corporation, signed and sealed by Christopher B. Shiver, P.E.

**B TESTS**

- 1 Test reports on
  - 1) Air Infiltration Test, per FBC, TAS 202-94
  - 2) Uniform Static Air Pressure Test, Loading per FBC TAS 202-94
  - 3) Water Resistance Test, per FBC, TAS 202-94
  - 4) Cyclic Wind Pressure Loading per FBC, TAS 203-94along with marked-up drawings and installation diagram , prepared by Hurricane Test Laboratory, LLC, Report No. G064-0605-06, dated June 22, 2006, signed and sealed by Vinu J. Abraham, P.E.

**C CALCULATIONS**

- 1 Calculations for R-Wall Class PB EIFS over plywood sheathing, sheets 1 through 5, dated 06/16/97, prepared by Cerny & Ivey Engineers, Inc., signed and sealed by A. C. Ivey , PE.
- 2 Calculations for R-Wall Class B System, sheets 1 through 52, signed and sealed by A. C. Ivey, PE on 11/04/99.

**D QUALITY ASSURANCE**

1. Miami Dade Building Code Compliance Office (BCCO).

**E MATERIAL CERTIFICATION**

- 1 None

**F STATEMENTS.**

- 1 Test compliance letter issued by Hurricane Test Laboratory, Inc. on 06/22/07, signed and sealed by Vinu J. Abraham, P.E.
- 2 Code compliance letter issued by Cerny & Ivey Engineers, Inc., dated 03/30/07, signed and sealed by Christopher B. Shiver, P.E.
- 3 No change letter issued by Sto Corporation, on 01/31/2001, signed by T. E. Remmele.

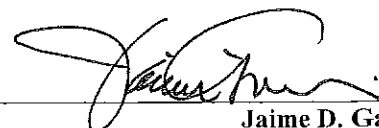

Jaime D. Gascon, P.E.  
Chief, Product Control Division  
NOA No: 07-0104.05  
Expiration Date: January 08, 2012  
Approval Date: April 26, 2007

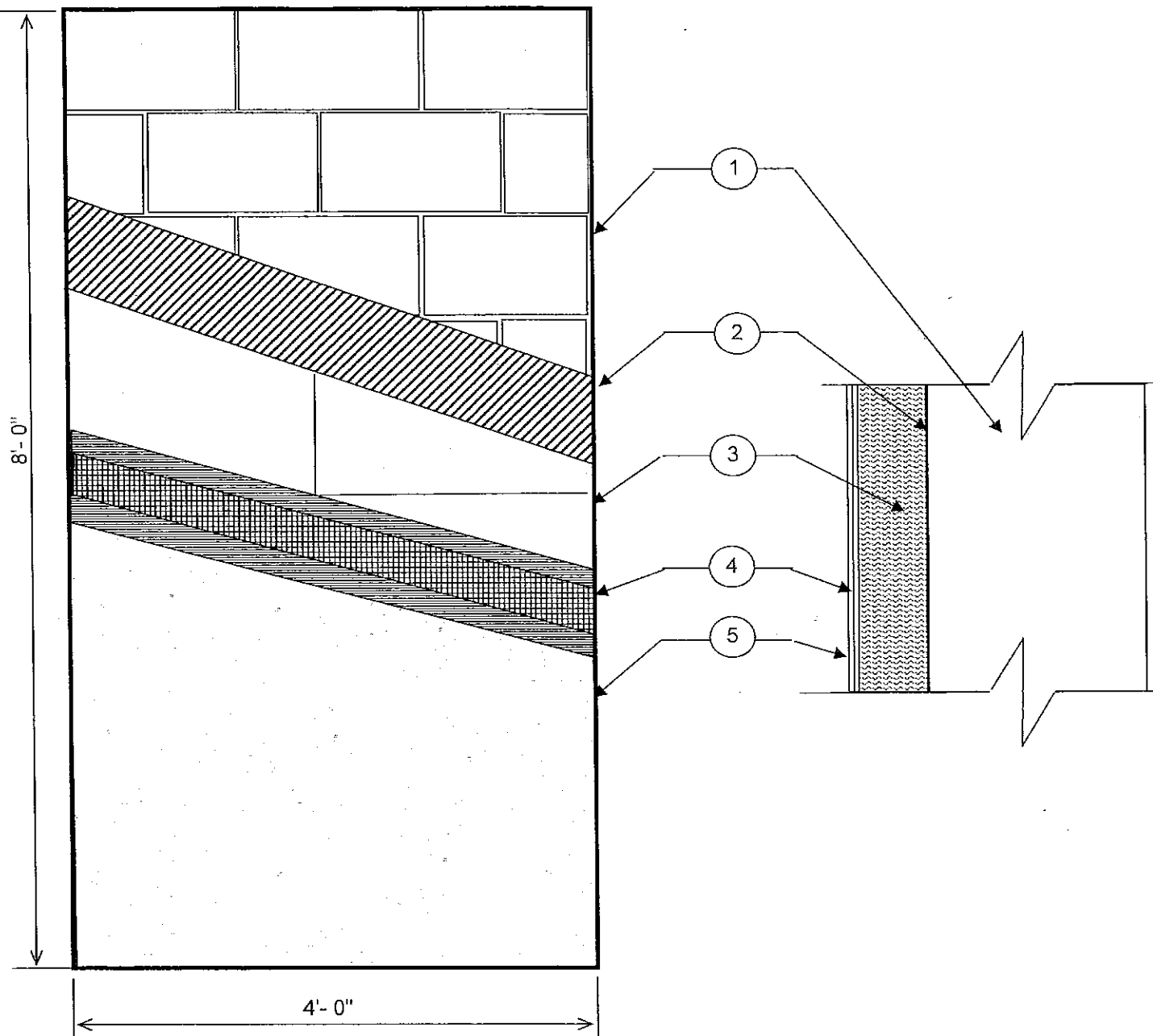

**KEY:**

1. Nominal 8-inch Hollow Core Concrete Blocks
2. Sto Primer/Adhesive-B
3. EPS board @ 1" thick & 1 pcf by Carpenter
4. Sto Primer/Adhesive -B (No. 101) with Sto Mesh (No. 920) embedded
5. Sto Textured Finish No. 310, 306, and 307

**DESCRIPTION:**

**1.1 Sto Insulation and Finish System**

- 1.1.1 Sto insulation (Carpenter) EPS Expanded Polystyrene insulation minimum 1" thick with a density of 1 pcf as approved by Miami-Dade County NOA # 01.0718.02.
- 1.1.2 Sto Primer/Adhesive-B (No. 101) is a polymer modified cement based material used as an adhesive and base coat in Sto systems.
- 1.1.3 Sto reinforcing mesh (No. 920) is a glass fiber fabric used for impact resistance of the Sto systems.
- 1.1.4 Sto textured finishes (No. 310, 306, and 307) are ready-mixed acrylic-based exterior or interior textured finishes used as decoration and protection with the Sto systems. Three are available: Fine Sand, Medium Sand and Swirl.

**1.2 Application**

- 1.2.1 The exposed CMU surface is cleaned to remove any bond inhibiting particles from the application surface.
- 1.2.2 The Sto Primer/Adhesive-B (No. 101) is mixed with 7-9 quarts of water using a clean high-speed electric drill and paddle. The mixture is allowed to set for approximately 5 minutes and then remixed to a uniform consistency. The adhesive is applied to the back of the Sto (Carpenter) insulation board using a 5/8" x 5/8" square-notched trowel. Uniform ribbons of adhesive are formed on the Sto (Carpenter) insulation board parallel to the long dimension of the board.
- 1.2.3 The Sto (Carpenter) insulation board, minimum 1" thick is applied to the CMU surface horizontally with staggered joints. Uniform pressure is applied to the insulation board to ensure proper adhesion to the plywood surface. Once the entire surface of the CMU is covered with the insulation board it is left overnight to dry.
- 1.2.4 The Sto Primer/Adhesive-B (No. 101) is mixed with 7-9 quarts of water using a clean high-speed electric drill and paddle. The mixture is allowed to set for approximately 5 minutes and then remixed to a uniform consistency. A 1/8 inch thick layer is applied to the exposed surface of the Sto (Carpenter) insulation board using a stainless steel trowel.
- 1.2.5 Sto Mesh is embedded in the wet Primer/Adhesive-B by troweling from the center of the mesh to the edges of the mesh and the excess Primer/Adhesive-B is removed. This process is repeated until the entire exposed area of the insulation board is covered with mesh. The final thickness of the Primer/Adhesive-B is a minimum 1/16". The Primer/Adhesive-B is allowed to dry for a minimum of 12 hours.
- 1.2.6 Once the mesh reinforcing coats are dry and cured, a minimum 1/16" coat of Sto textured finish is applied to the entire surface.

**PRODUCT RENEWED**  
 as complying with the Florida  
 Building Code  
 Acceptance No. 07-0104.05  
 Expiration Date 01/08/2012  
 By *[Signature]*  
 Miami Dade Product Control  
 Division

**GENERAL NOTES:**

- 1) This system has been designed in accordance with the 2004 Florida Building Code and its latest supplements.
- 2) This system has been tested in accordance with the Florida Building Code Protocols TAS-202 and TAS-203 Structural and Cyclic Testing.
- 3) This system shall be applied by a licensed plastering contractor following the recommendations of Sto Corp., this notice of acceptance and applicable sections of the Florida Building Code.
- 4) The engineer and/or architect of record for each project using this system shall size the stud framing to ensure conformance with stud deflection and stress limitations as required by governing codes and this document.
- 5) Insulation boards shall be placed in a running bond pattern.
- 6) All concrete masonry units shall comply with ASTM C90 and Type S mortar per ASTM C270.
- 8) Details on page No.s 2 and 3 of 3 are typical and show intent to prevent water infiltration into and behind the system. Alternate details and specific conditions not covered by the typical details are the responsibility of the licensed design professional in consultation with Sto Corp.

**Design Pressure Rating  
 -100 psf**

Installed over Impact Resistant Substrate

**Sto Corp.**  
 3800 Camp Creek Parkway  
 Building 1400, Suite 120  
 Atlanta, GA 30331  
 Large Missile Impact  
 Resistance  
**Sto HI-CM**  
 Date: 3-29-07  
 Not To Scale

*[Signature]*

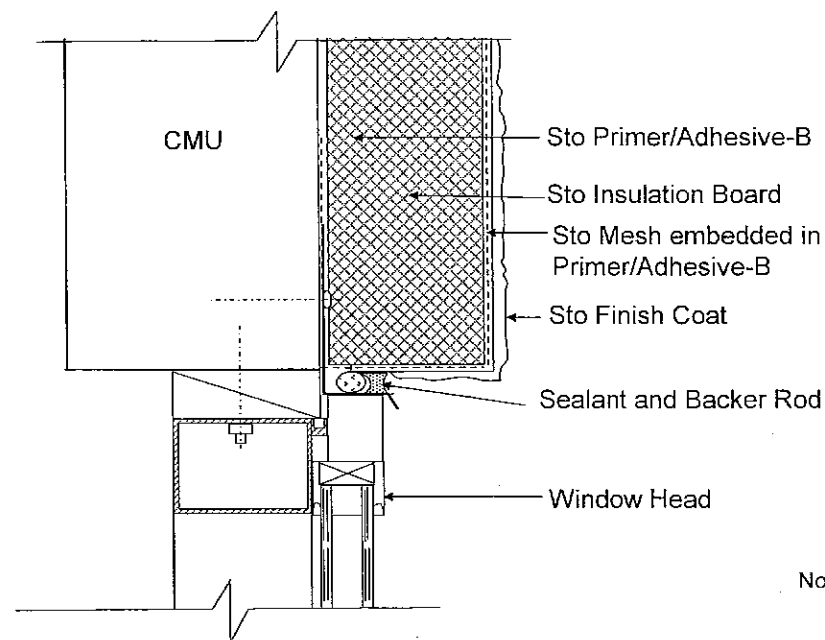

Notes:

1. Provide minimum 3/4-inch (19 mm) depth from back of insulation board to face of window frame for sufficient depth to install sealant.
2. Provided minimum 1/2-inch (13 mm) sealant joint width.
3. Provide flashing as secondary barrier at sealant joint.

**Window Head**

N.T.S.

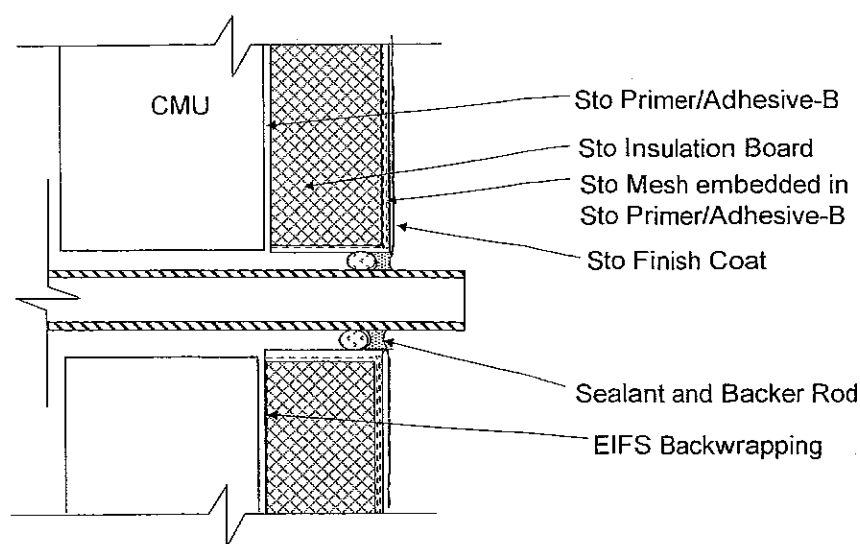

Note: Provide minimum 1/2-in. (13mm) sealant joint width.

**Termination at Penetration**

N.T.S.

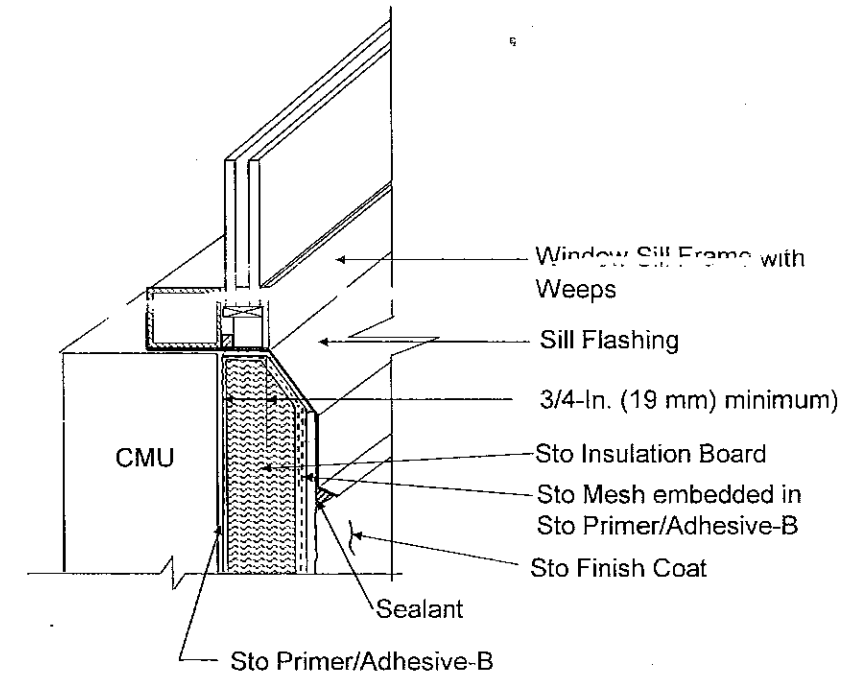

Notes:

1. Protect EIF system at sill from weather damage during construction until permanently protected with sill and sealant
2. Pan up and seal flashing at jamb.

**Window Sill**

N.T.S.

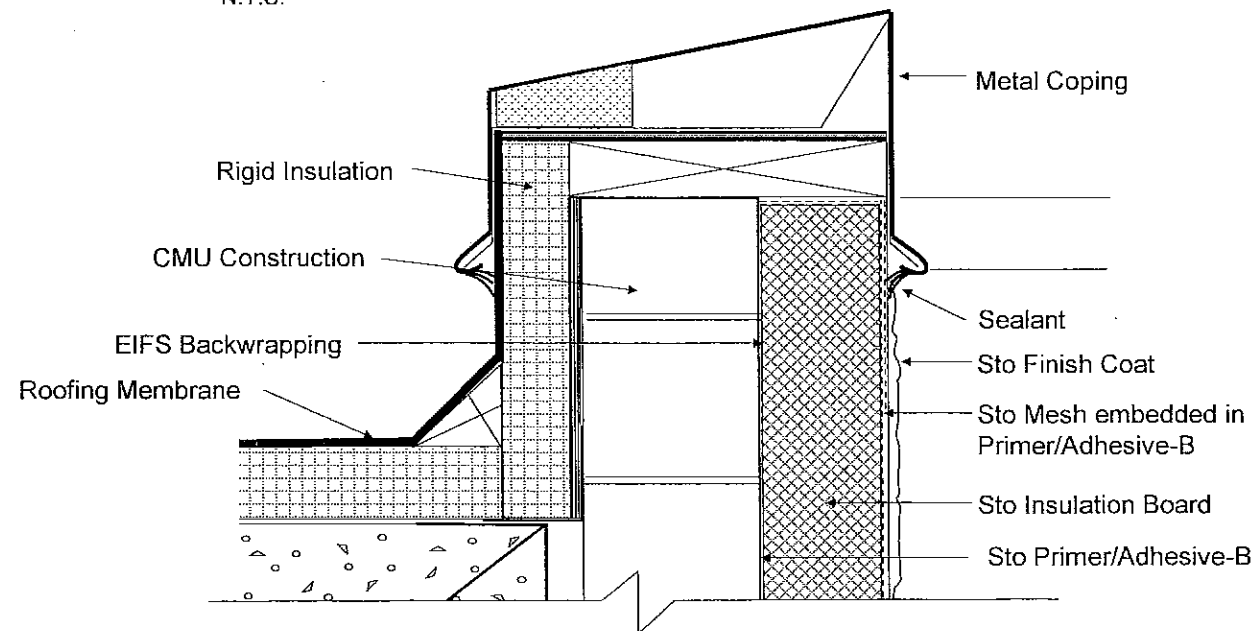

Notes:

1. Protect exposed parapet from weather damage during construction until permanently protected by coping.
2. Extend dimension of coping overlap for multistory construction/coastal regions to prevent wind driven rain from entering behind the system.

**Parapet**

N.T.S.

**TYPICAL DETAILS**

**PRODUCT RENEWED**  
 as complying with the Florida  
 Building Code  
 Acceptance No 07-0104-05  
 Expiration Date 01/29/2012  
 By *[Signature]*  
 Miami Code Product Control  
 Division

**Sto Corp.**  
 3800 Camp Creek  
 Parkway  
 Building 1400, Suite 120  
 Atlanta, GA 30331

Large Missile Impact  
 Resistance

**Sto HI-CM**  
 Page No. 2 of 3

Date: 3-29-07

Not To Scale

*[Handwritten Signature]*

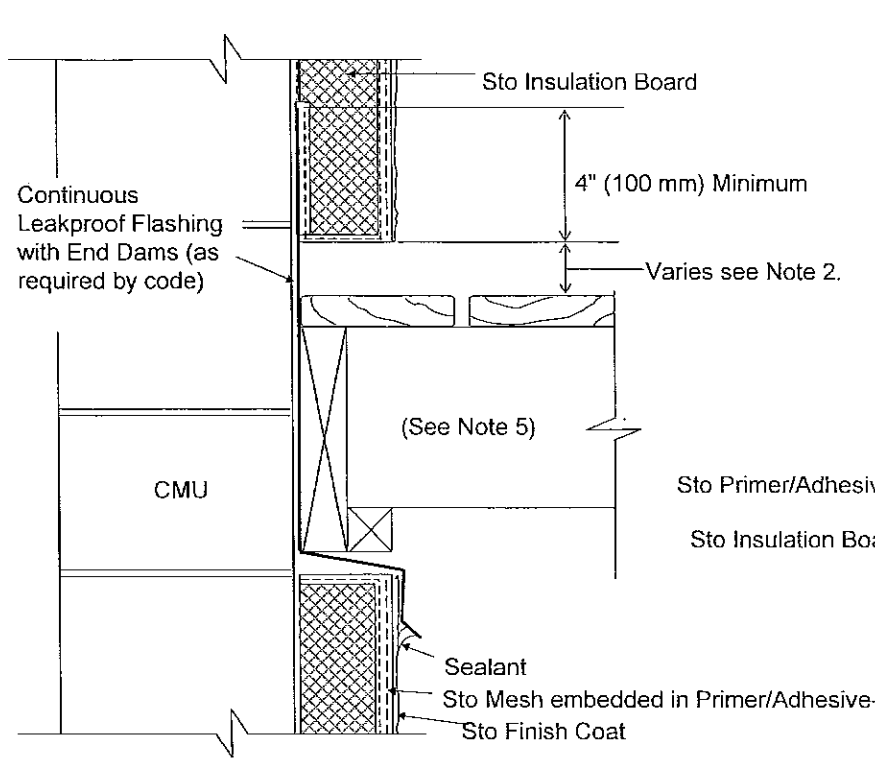

- Notes:**
- 1 Seal penetrations through flashing where attached to CMU.
  2. Distance of EIFS to deck varies with climate. Allow sufficient distance to prevent snow/ice and puddling of water against system.
  3. Provide end dams where flashings terminate at ends of deck.
  4. Pressure treated wood (space from flashing or rout backside to provide drainage).

**TERMINATION AT DECK**

N.T.S

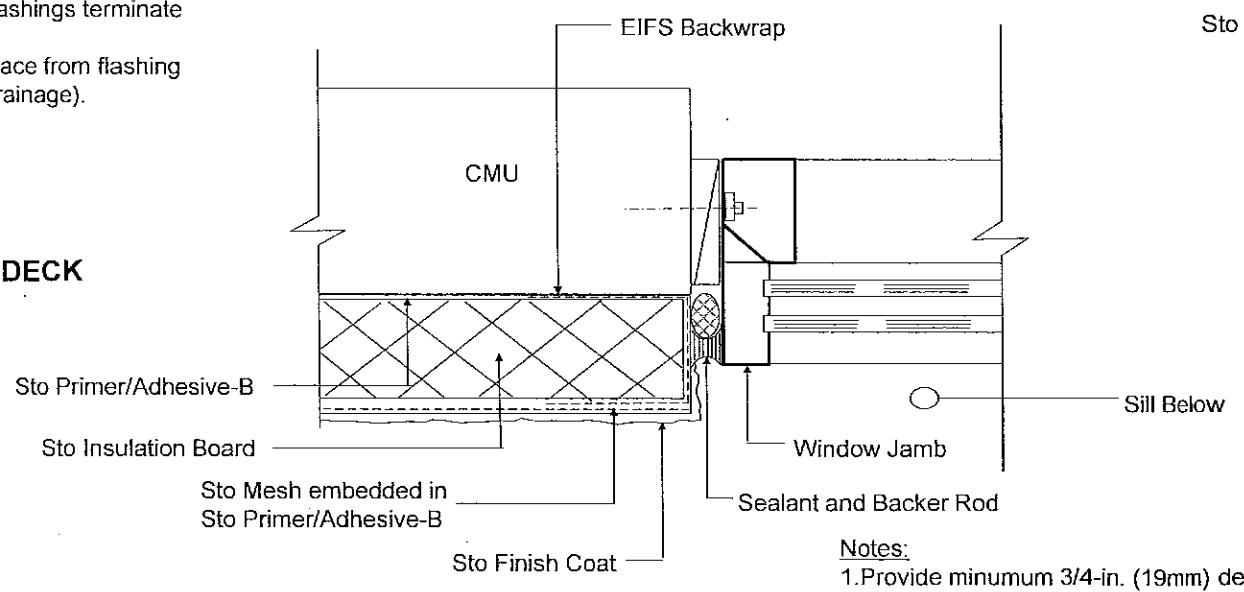

**WINDOW JAMB**

N.T.S

- Notes:**
1. Provide minimum 3/4-in. (19mm) depth from back of insulation board to face of window frame for sufficient depth to install sealant.
  2. Provided minimum 1/2-in. (13 mm) sealant joint width.

- Notes:**
1. Provide minimum 3/4-inch (19 mm) sealant joint.

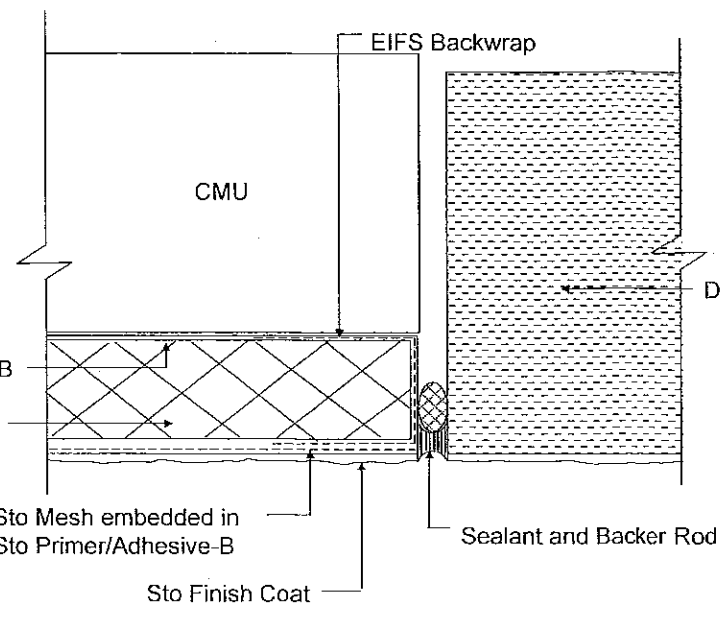

**CONSTRUCTION JOINT**

N.T.S

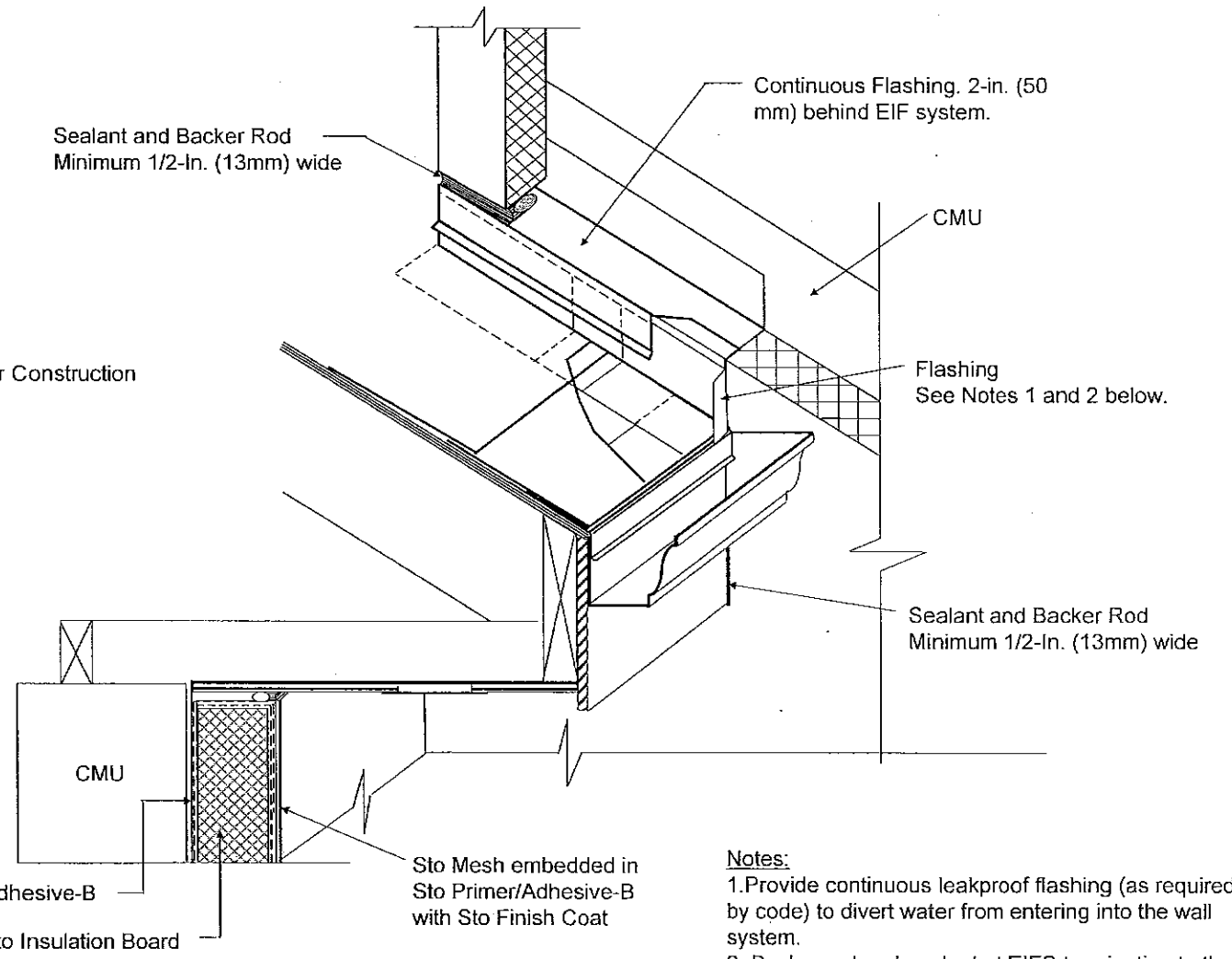

**OVERHANG**

N.T.S

- Notes:**
1. Provide continuous leakproof flashing (as required by code) to divert water from entering into the wall system.
  2. Backer rod and sealant at EIFS termination to the diverter flashing to prevent water from penetrating behind the EIFS.

**TYPICAL DETAILS**

**PRODUCT RENEWED**  
 as complying with the Florida  
 Building Code  
 Acceptance No. 07-0104.05  
 Expiration Date 01/08/2012  
 By *[Signature]*  
 Miami Dade Product Control  
 Division

*[Signature]*

**Sto Corp.**  
 3800 Camp Creek  
 Parkway  
 Building 1400, Suite 120  
 Atlanta, GA 30331

Large Missile Impact  
 Resistance  
**Sto HI-CM**  
 Page No. 3 of 3  
 Date: 3-29-07  
 Not To Scale